

Data Sheet: MSTS Series Fluid Temperature Sensor

Part Number: MSTS-2P-M12C-AL-G15

Type: Closed Element Thermistor
 Element Encapsulation: Glass
 Housing: Hard Anodized Alloy
 Temp. Range: -30°C to 150°C
 -22°F to 302°F
 Hex Size: 19 mm
 Thread Size: M12 x 1.5
 Connection: DTM04-2P, 2 Pin
 Mating connector: DTM06-2S

Side View:

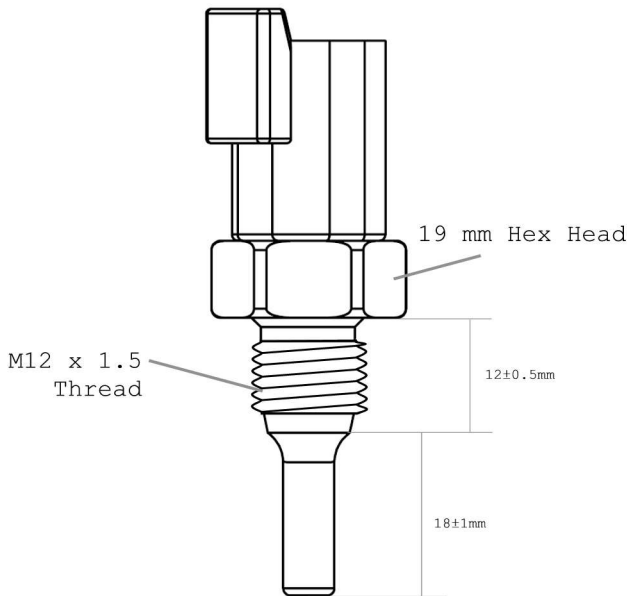

Rear View:

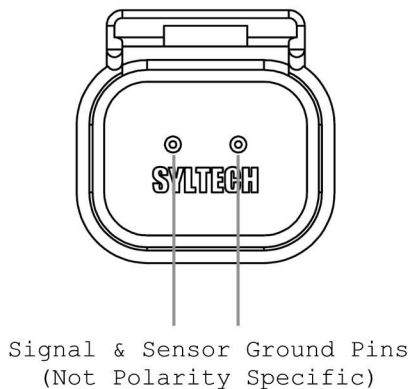

Calibration Table:

| Temperature (°C/°F) | Resistance (Ω) | Voltage (V) 1kΩ Pull-Up @ 5VDC |
|---------------------|----------------|-----------------------------------|
| -30 / -22 | 50601 | 4.903 |
| -25 / -13 | 36877 | 4.868 |
| -20 / -4 | 27192 | 4.823 |
| -15 / 5 | 20274 | 4.765 |
| -10 / 14 | 15275 | 4.693 |
| -5 / 23 | 11622 | 4.604 |
| 0 / 32 | 8926 | 4.496 |
| 5 / 41 | 6916 | 4.368 |
| 10 / 50 | 5404 | 4.219 |
| 15 / 59 | 4256 | 4.049 |
| 20 / 68 | 3378 | 3.858 |
| 25 / 77 | 2700 | 3.649 |
| 30 / 86 | 2172 | 3.424 |
| 35 / 95 | 1760 | 3.188 |
| 40 / 104 | 1434 | 2.946 |
| 45 / 113 | 1176 | 2.702 |
| 50 / 122 | 970 | 2.462 |
| 55 / 131 | 804 | 2.228 |
| 60 / 140 | 670 | 2.006 |
| 65 / 149 | 561 | 1.757 |
| 70 / 158 | 472 | 1.603 |
| 75 / 167 | 399 | 1.426 |
| 80 / 176 | 338 | 1.263 |
| 85 / 185 | 288 | 1.118 |
| 90 / 194 | 247 | 0.990 |
| 95 / 203 | 212 | 0.875 |
| 100 / 212 | 183 | 0.773 |
| 105 / 221 | 158 | 0.682 |
| 110 / 230 | 137 | 0.602 |
| 115 / 239 | 120 | 0.536 |
| 120 / 248 | 105 | 0.475 |
| 125 / 257 | 92 | 0.421 |
| 130 / 266 | 80 | 0.370 |
| 135 / 275 | 71 | 0.318 |
| 140 / 284 | 63 | 0.283 |
| 145 / 293 | 56 | 0.252 |
| 150 / 302 | 49 | 0.234 |

Note: Metal hex head section must be used to tighten sensor only. Rotational force on the plastic connector body can potentially cause damage to the sensor assembly. Syltech takes no responsibility for any damage incurred by incorrect installation or use of this sensor. If unsure, please consult a qualified Auto Electrician for correct fitment and wiring. Off-road use only.