

Data Sheet: MST5 Series Air Temperature Sensor

Part Number: MST5-2P-M14-AL-G25

Type: Open Element Thermistor
Element Encapsulation: Glass
Housing: Hard Anodized Alloy
Temp. Range: -40°C to 250°C
-40°F to 482°F

Hex Size: 19 mm

Thread Size: M14 x 1.5

Connection: DTM04-2P, 2 Pin

Mating connector: DTM06-2S

Side View:

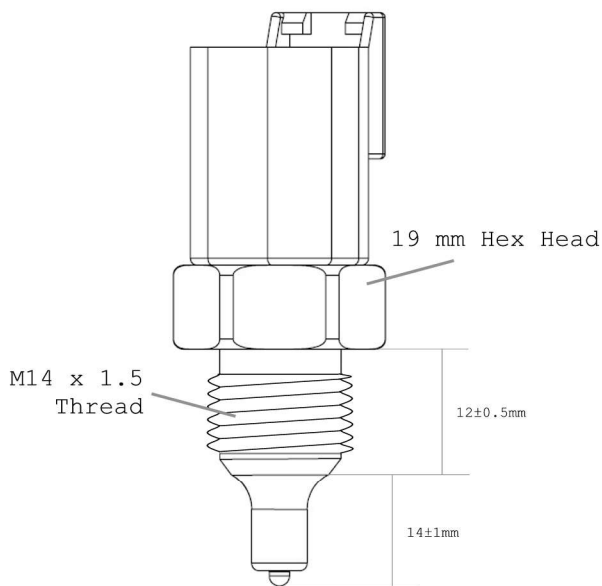

Rear View:

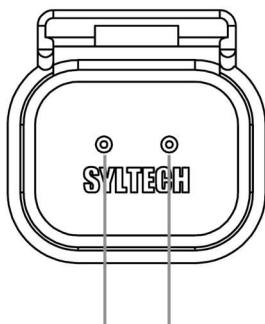

Signal & Sensor Ground Pins
(Not Polarity Specific)

Calibration Table:

Temperature (°C / °F)	Resistance (Ω)	Voltage (V) 1kΩ Pull-Up @ 5VDC
-40 / -40	343633	4.99
-30 / -22	179267	4.97
-20 / -4	97840	4.95
-10 / 14	55595	4.91
0 / 32	32755	4.85
10 / 50	19938	4.76
20 / 68	12501	4.63
30 / 86	8051	4.45
40 / 104	5315	4.21
50 / 122	3588	3.91
60 / 140	2473	3.56
70 / 158	1738	3.17
80 / 176	1243	2.77
90 / 194	904	2.37
100 / 212	668	2.00
110 / 230	500	1.67
120 / 248	380	1.38
130 / 266	292	1.13
140 / 284	227	0.93
150 / 302	179	0.76
160 / 320	143	0.62
170 / 338	115	0.51
180 / 356	93	0.43
190 / 374	76	0.35
200 / 392	63	0.30
210 / 410	53	0.25
220 / 428	44	0.21
230 / 446	37	0.18
240 / 464	32	0.15
250 / 482	27	0.13

Note: PVC cap must be removed before installation. Metal hex head section must be used to tighten the sensor only. Rotational force on the plastic connector body can potentially cause damage to the sensor assembly. Syltech takes no responsibility for any damage incurred by incorrect installation or use of this sensor. If unsure, please consult a qualified Auto Electrician for correct fitment and wiring. Off-road use only.