

Data Sheet: MSTS Series Fluid Temperature Sensor

Part Number: MSTS-2P-M12C-AL-TOY

Type: Closed Element Thermistor
Element Encapsulation: Glass
Housing: Hard Anodized Alloy
Temp. Range: -40°C to 150°C
-40°F to 302°F
Hex Size: 19 mm
Thread Size: M12 x 1.5
Connection: DTM04-2P, 2 Pin
Mating connector: DTM06-2S

Side View:

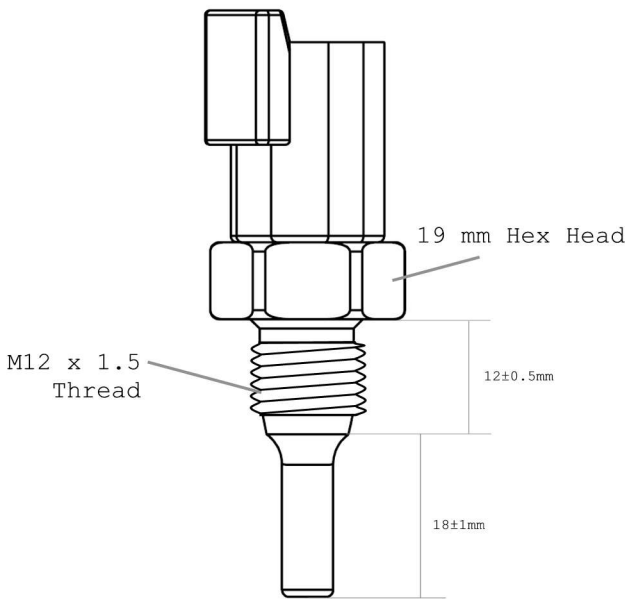

Rear View:

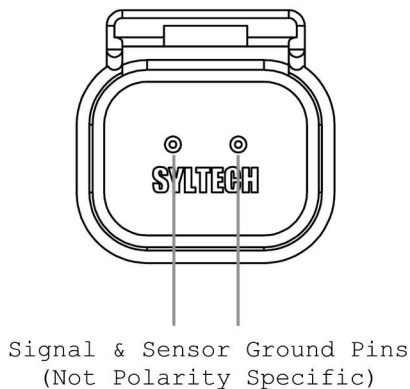

Calibration Table:

Temperature (°C/°F)	Resistance (Ω)	Voltage (V) 1kΩ Pull-Up @ 5VDC
-40/-40	45359	4.89
-35/-31	33864	4.86
-30/-22	25550	4.81
-25/-13	19469	4.76
-20/ -4	14976	4.69
-15/ 5	11622	4.60
-10/ 14	9095	4.50
-5 / 23	7175	4.39
0 / 32	5702	4.25
5 / 41	4565	4.10
10 / 50	3679	3.93
15 / 59	2984	3.74
20 / 68	2436	3.54
25 / 77	2000	3.33
30 / 86	1651	3.11
35 / 95	1371	2.89
40 / 104	1144	2.67
45 / 113	959	2.45
50 / 122	808	2.23
55 / 131	684	2.03
60 / 140	581	1.84
65 / 149	496	1.66
70 / 158	425	1.49
75 / 167	366	1.34
80 / 176	316	1.20
85 / 185	274	1.08
90 / 194	238	0.96
95 / 203	208	0.86
100 / 212	182	0.77
105 / 221	160	0.69
110 / 230	141	0.62
115 / 239	124	0.55
120 / 248	110	0.50
125 / 257	98	0.45
130 / 266	87	0.40
135 / 275	78	0.36
140 / 284	70	0.33
145 / 293	62	0.29
150 / 302	56	0.27

Note: Metal hex head section must be used to tighten sensor only. Rotational force on the plastic connector body can potentially cause damage to the sensor assembly. Syltech takes no responsibility for any damage incurred by incorrect installation or use of this sensor. If unsure, please consult a qualified Auto Electrician for correct fitment and wiring. Off-road use only.