

Data Sheet: MST5 Series Air Temperature Sensor

Part Number: MST5-2P-LAT-TI-G15

Type: Open Element Thermistor  
Element Encapsulation: Glass  
Housing: GR5 Titanium  
Temp. Range: -30°C to 150°C  
                  -22°F to 302°F  
Hex Size: 12 mm  
Thread Size: 1/8" NPT  
Connection: DTM04-2P, 2 Pin  
Mating connector: DTM06-2S

Side View:

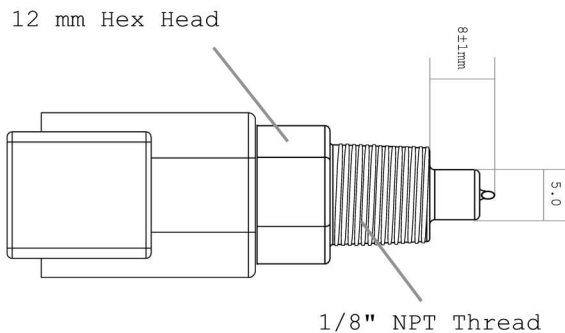

Rear View:

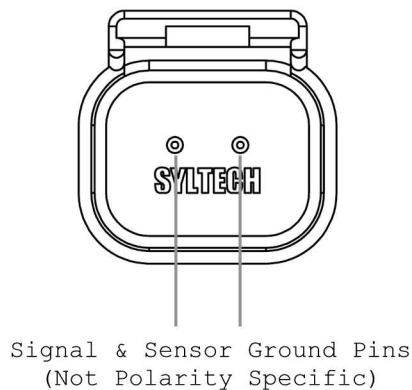

Calibration Table:

Temperature (°C/°F)	Resistance (Ω)	Voltage (V) 1kΩ Pull-Up @ 5VDC
-30 / -22	<b>50601</b>	<b>4.903</b>
-25 / -13	36877	4.868
-20 / -4	<b>27192</b>	<b>4.823</b>
-15 / 5	20274	4.765
-10 / 14	<b>15275</b>	<b>4.693</b>
-5 / 23	11622	4.604
0 / 32	<b>8926</b>	<b>4.496</b>
5 / 41	6916	4.368
10 / 50	<b>5404</b>	<b>4.219</b>
15 / 59	4256	4.049
20 / 68	<b>3378</b>	<b>3.858</b>
25 / 77	2700	3.649
30 / 86	<b>2172</b>	<b>3.424</b>
35 / 95	1760	3.188
40 / 104	<b>1434</b>	<b>2.946</b>
45 / 113	1176	2.702
50 / 122	<b>970</b>	<b>2.462</b>
55 / 131	804	2.228
60 / 140	<b>670</b>	<b>2.006</b>
65 / 149	561	1.757
70 / 158	<b>472</b>	<b>1.603</b>
75 / 167	399	1.426
80 / 176	<b>338</b>	<b>1.263</b>
85 / 185	288	1.118
90 / 194	<b>247</b>	<b>0.990</b>
95 / 203	212	0.875
100 / 212	<b>183</b>	<b>0.773</b>
105 / 221	158	0.682
110 / 230	<b>137</b>	<b>0.602</b>
115 / 239	120	0.536
120 / 248	<b>105</b>	<b>0.475</b>
125 / 257	92	0.421
130 / 266	<b>80</b>	<b>0.370</b>
135 / 275	71	0.318
140 / 284	<b>63</b>	<b>0.283</b>
145 / 293	56	0.252
150 / 302	<b>49</b>	<b>0.234</b>

Note: Metal hex head section must be used to tighten the sensors only. Rotational force on the plastic connector body can potentially cause damage to the sensor assembly. Syltech takes no responsibility for any damage incurred by incorrect installation or use of this sensor. If unsure, please consult a qualified Auto Electrician for correct fitment and wiring. Off-road use only.