

Data Sheet: MSTS Series Air Temperature Sensor

Part Number: MSTS-2P-IAT-TI-E20

Type: Open Element Thermistor  
 Housing: GR5 Titanium  
 Temp. Range: -30°C to 200°C  
                   -22°F to 392°F  
 Hex Size: 12 mm  
 Thread Size: 1/8" NPT  
 Connection: DTM04-2P, 2 Pin  
 Mating connector: DTM06-2S

Side View:

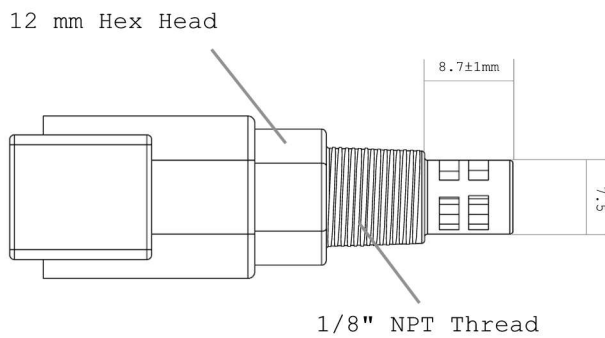

Rear View:

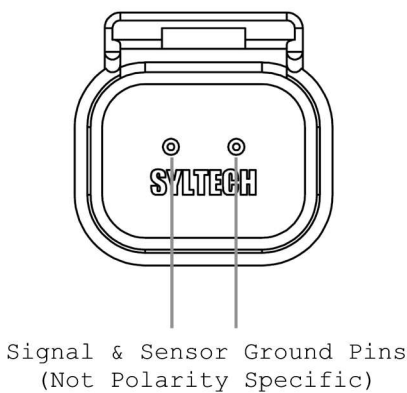

Calibration Table:

Temperature (°C/°F)	Resistance (Ω)	Voltage (V) 1kΩ Pull-Up @ 5VDC
-30 / -22	179266	4.972
-25 / -13	131733	4.970
-20 / -4	97839	4.949
-15 / 5	73401	4.933
-10 / 14	55595	4.912
-5 / 23	42490	4.885
0 / 32	32754	4.852
5 / 41	25456	4.811
10 / 50	19938	4.761
15 / 59	15731	4.701
20 / 68	12500	4.630
25 / 77	10000	4.545
30 / 86	8051	4.448
35 / 95	6522	4.335
40 / 104	5314	4.208
45 / 113	4355	4.066
50 / 122	3588	3.910
55 / 131	2971	3.741
60 / 140	2473	3.560
65 / 149	2068	3.370
70 / 158	1738	3.174
75 / 167	1466	2.972
80 / 176	1243	2.771
85 / 185	1058	2.570
90 / 194	904	2.374
95 / 203	775	2.183
100 / 212	667	2.001
105 / 221	576	1.827
110 / 230	500	1.667
115 / 239	435	1.516
120 / 248	379	1.374
125 / 257	332	1.246
130 / 266	292	1.130
135 / 275	257	1.022
140 / 284	227	0.925
145 / 293	201	0.837
150 / 302	179	0.759
155 / 311	159	0.686
160 / 320	142	0.622
165 / 329	127	0.563
170 / 338	114	0.512
175 / 347	103	0.467
180 / 356	93	0.425
185 / 365	84	0.387
190 / 374	76	0.353
195 / 383	69	0.323
200 / 392	63	0.296

Optional higher range if needed.

Note: Metal hex head section must be used to tighten the sensors only. Rotational force on the plastic connector body can potentially cause damage to the sensor assembly. Syltech takes no responsibility for any damage incurred by incorrect installation or use of this sensor. If unsure, please consult a qualified Auto Electrician for correct fitment and wiring. Off-road use only.