



PN: MSTS-2P-CLT-SS-E15
 Rev 1.11 202301
 www.syltech.com.au

Data Sheet: MSTS Series Fluid Temperature Sensor

Part Number: MSTS-2P-CLT-SS-E15

Type: Closed Element Thermistor
 Housing: Stainless Steel 304L
 Temp. Range: -30°C to 150°C
 -22°F to 302°F
 Hex Size: 12 mm
 Thread Size: 1/8" NPT
 Connection: DTM04-2P, 2 Pin
 Mating connector: DTM06-2S

Side View:

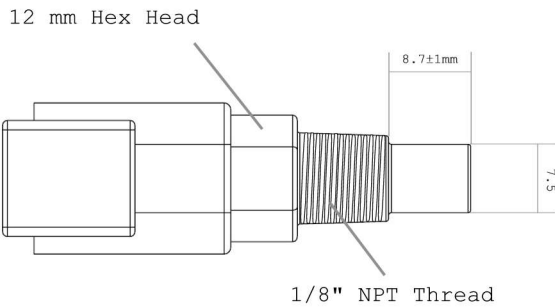

Rear View:

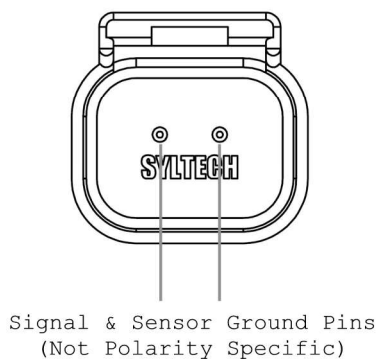

Calibration Table:

Temperature (°C/°F)	Resistance (Ω)	Voltage (V) 1kΩ Pull-Up @ 5VDC
-30 / -22	50601	4.903
-25 / -13	36877	4.868
-20 / -4	27192	4.823
-15 / 5	20274	4.765
-10 / 14	15275	4.693
-5 / 23	11622	4.604
0 / 32	8926	4.496
5 / 41	6916	4.368
10 / 50	5404	4.219
15 / 59	4256	4.049
20 / 68	3378	3.858
25 / 77	2700	3.649
30 / 86	2172	3.424
35 / 95	1760	3.188
40 / 104	1434	2.946
45 / 113	1176	2.702
50 / 122	970	2.462
55 / 131	804	2.228
60 / 140	670	2.006
65 / 149	561	1.757
70 / 158	472	1.603
75 / 167	399	1.426
80 / 176	338	1.263
85 / 185	288	1.118
90 / 194	247	0.990
95 / 203	212	0.875
100 / 212	183	0.773
105 / 221	158	0.682
110 / 230	137	0.602
115 / 239	120	0.536
120 / 248	105	0.475
125 / 257	92	0.421
130 / 266	80	0.370
135 / 275	71	0.318
140 / 284	63	0.283
145 / 293	56	0.252
150 / 302	49	0.234

Note: Metal hex head section must be used to tighten the sensors only. Rotational force on the plastic connector body can potentially cause damage to the sensor assembly. Syltech takes no responsibility for any damage incurred by incorrect installation or use of this sensor. If unsure, please consult a qualified Auto Electrician for correct fitment and wiring. Off-road use only.